



WINKEL-Rolle
axial über Exzenter justierbar

■ Rollen lebensdauer geschmiert



WINKEL-Rolle
Justierung der Axialrolle
über Exzenter bis 4.461
Adjustment of axial
bearing with eccentric
up to 4.461



WINKEL Jumbo-Rolle
Justierung der Axialrolle
über Exzenter ab 4.462
Adjustment of axial
bearing with eccentric
from 4.462

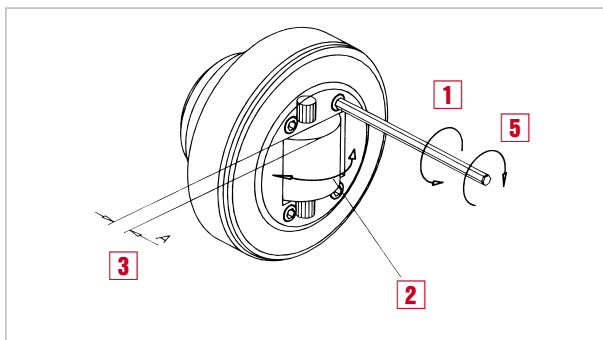

CAD Download in 2D/3D unter www.winkel.de

WINKEL Bearing
axial bearing eccentric adjustable

■ bearings are lubricated for life

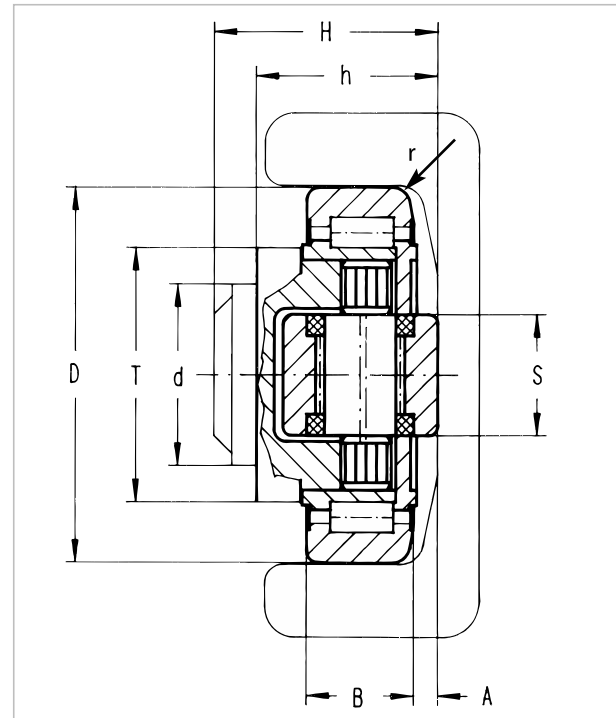

Justierung der Axialrolle

- 1 Deckelschrauben lösen
- 2 Exzenterachse drehen (Axialrolle wird verdreht)
- 3 Maß A überprüfen (ggf. Punkt 2 wiederholen)
- 4 Schrauben mit Loctite sichern
- 5 Deckelschrauben festziehen

Adjusting of the axial bearing

- 1 loosen screws
- 2 turn eccentric axle (axial bearing will be turned)
- 3 check measure A (if necessary repeat Pos.2)
- 4 secure screws with loctite
- 5 lock screws

CAD download in 2D/3D at www.winkel.de

Typ Type	Artikel-Nr. Article no.	D -0.1 [mm]	T [mm]	d -0.05 [mm]	H [mm]	h [mm]	B [mm]	A [mm]	S [mm]	r [mm]
4.454	201.031.000	62,5	42	30	37,5 - 39,0	30,5 - 32,0	20,0	4,0 - 5,5	20	3
4.455	201.032.000	70,1	48	35	44,0 - 45,5	36,0 - 37,5	23,0	4,0 - 5,5	20	4,5
4.456	201.033.000	77,7	54	40	48,0 - 49,5	37,0 - 38,5	23,0	3,5 - 5,0	26	4,5
4.457	201.034.003	77,7	54	40	40,0 - 41,5	29,0 - 30,5	23,0	3,5 - 5,0	26	4,5
4.458	201.035.000	88,4	59	45	57,0 - 58,5	44,0 - 45,5	30,0	4,0 - 5,5	26	4
4.459	201.036.000	101,6	69	50	46,0 - 48,0	33,0 - 35,0	26,0	4,5 - 6,5	30	4
4.460	201.037.000	108,5	69	55	54,0 - 56,0	40,0 - 42,0	31,0	4,0 - 6,0	30	4
4.461	201.038.000	107,7	69	60	69,0 - 71,0	55,0 - 57,0	31,0	4,0 - 6,0	30	5
4.462	201.039.000	123,0	80	60	72,3 - 76,3	56,0 - 60,0	37,0	5,0 - 9,0	34	5
4.463	201.040.000	149,4	108	60	77,5 - 81,5	58,5 - 62,5	45,0	6,0 - 10,0	34	5
4.464	201.048.000	170,0	103	80	91,0 - 94,0	72,0 - 75,0	53,0	7,0 - 10,0	50	5
4.085	201.049.000	180,0	124	100	95,7 - 98,7	76,3 - 79,3	57,3	6,5 - 9,5	60	3

C = Dyn. Tragzahl Radiallager (ISO 281/1), C₀ = Stat. Tragzahl Radiallager (ISO 76)
 C_A = Dyn. Tragzahl Axiallager (ISO 281/1), C_{0A} = Stat. Tragzahl Axiallager (ISO 76)
 F_R = Tragzahl Radiallager zulässige Belastung zwischen Rolle und Profil
 F_A = Tragzahl Axiallager zulässige Belastung zwischen Rolle und Profil

NEW



Passende Anschraubplatten

Suitable flange plates



Abb. exemplarisch
fig. exemplary

Typ Type	Artikel-Nr. Article no.	A [mm]	B [mm]	C [mm]	D [mm]	E [mm]	Ø F [mm]	G	Ø H [mm]	t [mm]	Distanzsteckblech 0,5mm Washer 0.5mm		Distanzsteckblech 1,0mm Washer 1.0mm	
AP 0	212.003.000	100	60	40	40	80	10,5	M10	30	10	DS-0-0,5	238.020.000	DS-0-1,0	238.020.001
AP 1	212.004.000	120	80	50	50	90	12,5	M12	35	15	DS-1-0,5	238.021.000	DS-1-1,0	238.021.001
AP 2	212.005.000	120	80	50	50	90	12,5	M12	40	15	DS-2-0,5	238.021.000	DS-2-1,0	238.021.001
AP 3.1	212.006.001	160	100	60	60	120	17,0	M16	45	20	DS-3.1-0,5	238.105.000	DS-3.1-1,0	238.105.001
AP 4	212.007.001	180	120	80	80	140	17,0	M16	60	20	DS-4-0,5	238.023.000	DS-4-1,0	238.023.001
AP 6	212.008.000	200	150	100	100	160	17,0	M16	60	20	DS-6-0,5	238.024.000	DS-6-1,0	238.024.001

Anschraubplatten quadratisch Reihe AP-Q S. 90
Flange plates square series AP-Q page 90

Profile Seite 62 / 70
Profiles page 62 / 70

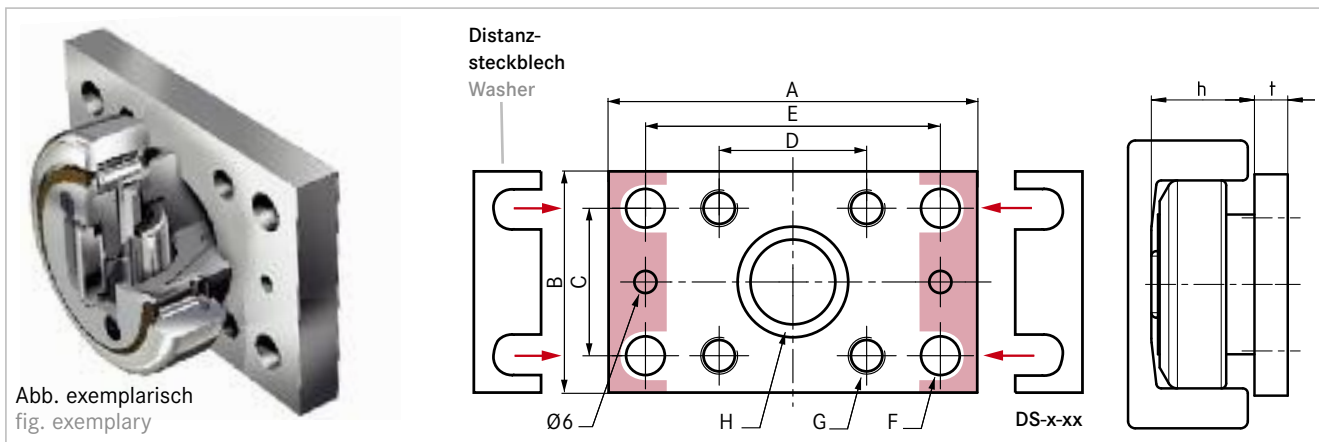
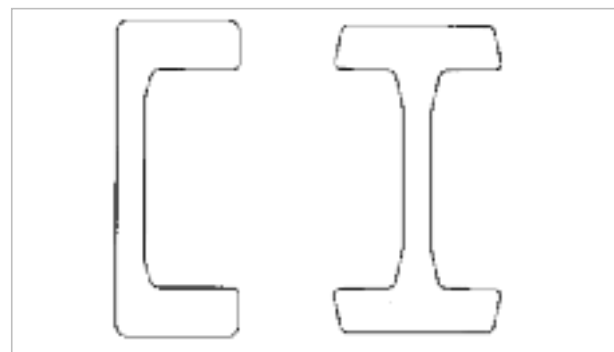
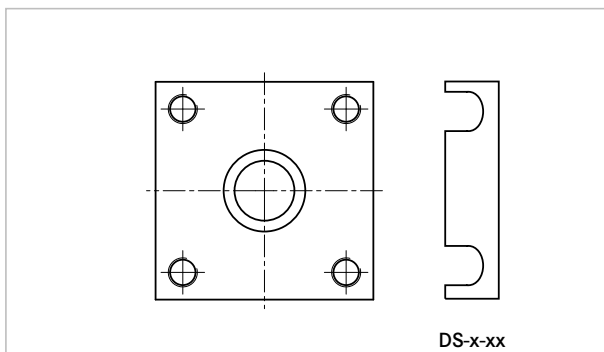

Typ Type	F_R [kN]	F_A [kN]	C [kN]	C_o [kN]	C_A [kN]	C_{oA} [kN]	Gewicht kg Weight kg	Anschraubplatten Flange plates		Profile Standard Profiles standard
4.454	10,30	3,20	31,0	35,5	11	11	0,53	AP0	AP0-Q	0 NbV
4.455	12,40	3,87	45,5	51,0	13	14	0,80	AP1	AP1-Q	1 NbV 3018 NbV
4.456	12,90	4,00	48,0	56,8	18	18	1,00	AP2	AP2-Q	2 NbV
4.457	12,90	4,00	48,0	56,8	18	18	0,87	-	-	3019 NbV
4.458	22,40	7,00	68,0	72,0	23	23	1,62	AP3.1	AP3-Q	3 NbV 3020 NbV
4.459	22,00	7,00	73,0	82,0	25	27	1,74	-	-	2912 NbV
4.460	23,80	7,44	81,0	95,0	31	36	2,27	-	-	3100 NbV
4.461	23,80	7,44	81,0	95,0	31	36	2,82	AP4	AP4-Q	4 NbV
4.462	33,90 (26,00)	10,60	110,0	132,0	43	50	3,60	AP4	AP4-Q	5 NbV (3353 NbV)
4.463	59,20	18,50	151,0	192,0	68	71	6,30	AP6	AP6-Q	6 NbV
4.464	72,00	18,50	217,0	269,0	70	83	9,95	-	AP89-Q	7 NbV®
4.085	91,80	23,70	266,0	500,0	100	180	11,50	-	AP90-Q	8 NbV

C = Dynamic load capacity radial bearing (ISO 281/1), C_o = Static load capacity radial bearing (ISO 76)
 C_A = Dynamic load capacity axial bearing (ISO 281/1), C_{oA} = Static load capacity axial bearing (ISO 76)
 F_R = Load capacity radial bearing max. allowable force between bearing and profile
 F_A = Load capacity axial bearing max. allowable force between bearing and profile